

INTEGREX IV (IGX 200 IV ST) – nástroje

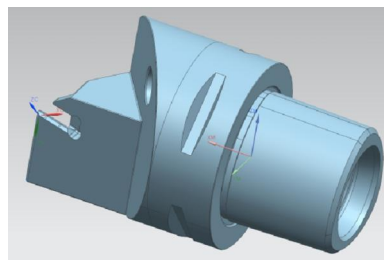

OBROBEK

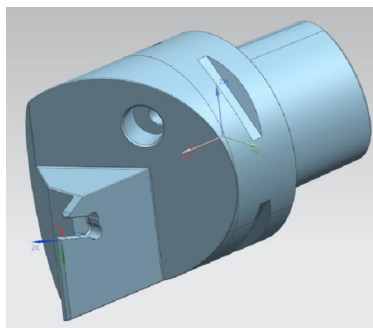

EFS-E44 20-42W20CF104

Monolitní fréza FINISHRED

$V = 150 \text{ m/min}$
 $fz = 0,08 \text{ mm}$



ECS035E04-3W06-57

Monolitní fréza

$V = 120 \text{ m/min}$
 $fz = 0,03 \text{ mm}$



EC-B3 03-08C06E50

Monolitní fréza

$V = 120 \text{ m/min}$
 $fz = 0,02 \text{ mm}$



EBM012A030-2C04

Kulová monolitní fréza

V = 45 m/min
(nedostatek otáček vřetena)
fz = 0,03 mm



EC-E4L 06-14/20W06CF57

Monolitní fréza Chatterfree

V = 120 m/min
fz = 0,03mm



H400 FR D050-06-22-12

Čelní nástrč.fr. s kruh. VBD

V = 200 m/min
fz = 0,25 mm



DCN 180-054-25A-3D
ICP 180 IC908

Těleso vrtáku SUMOCHAM
Vrtací hlavice

V = 110 m/min
f = 0,2 mm



DR-MF-16L-2.25D-20A-08
XCMT 080304-MF IC908

Těleso vrtáku DR-MF
Vyměnitelná destička

V = 180 m/min
fz = 0,25 mm



S20R SVJCR-11
VCGT 110302-AS IC20

Vnitřní držák
Vyměnitelná destička

n = 83 ot/min
f = 0,2 mm
ap = 2 mm



MWLNL 2525M-08W
WNMG 080404-GN IC8250

Vnější nožový držák
Vyměnitelná destička

V = 250 m/min
f = 0,45 mm
ap = 2 mm

