

# Variaxis 500-5XII-2PC – nástroje

## OBROBEK

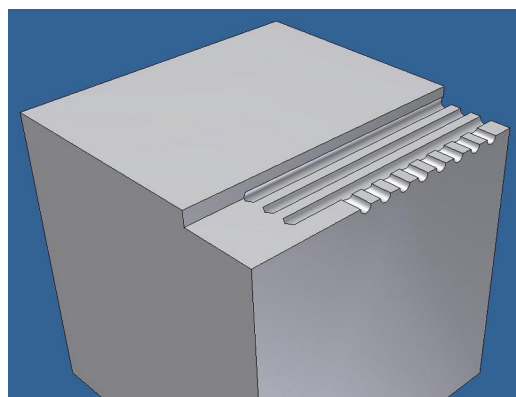

**SCD 080-043-080 ACG5**

**Monolitní vrták 5D**

**V = 80 m/min  
fn = 0,25 mm**



**SCD 080-160-080ACP20**

**Monolitní vrták 20D**

**V = 80 m/min  
fn = 0,22 mm**



**PHU025035X7R00**

**Fréza PLUNGER**

**V = 230 m/min  
fz = 0,15 mm**



**SJ5E063R00**

**Nástrčná fréza EVOTEC**

**V = 180 m/min  
fz = 0,187 mm**

