

$V_c=130\text{m/min}$
 $f_z=0,1\text{mm}$
 $a_p=5$
 $a_e=1$

Upínač
HydroGrip
392.410HMD-63 20 077

Fréza
R390-020A20L-11L
 $z=2$

VBD
R390-11T304E-PM
1030

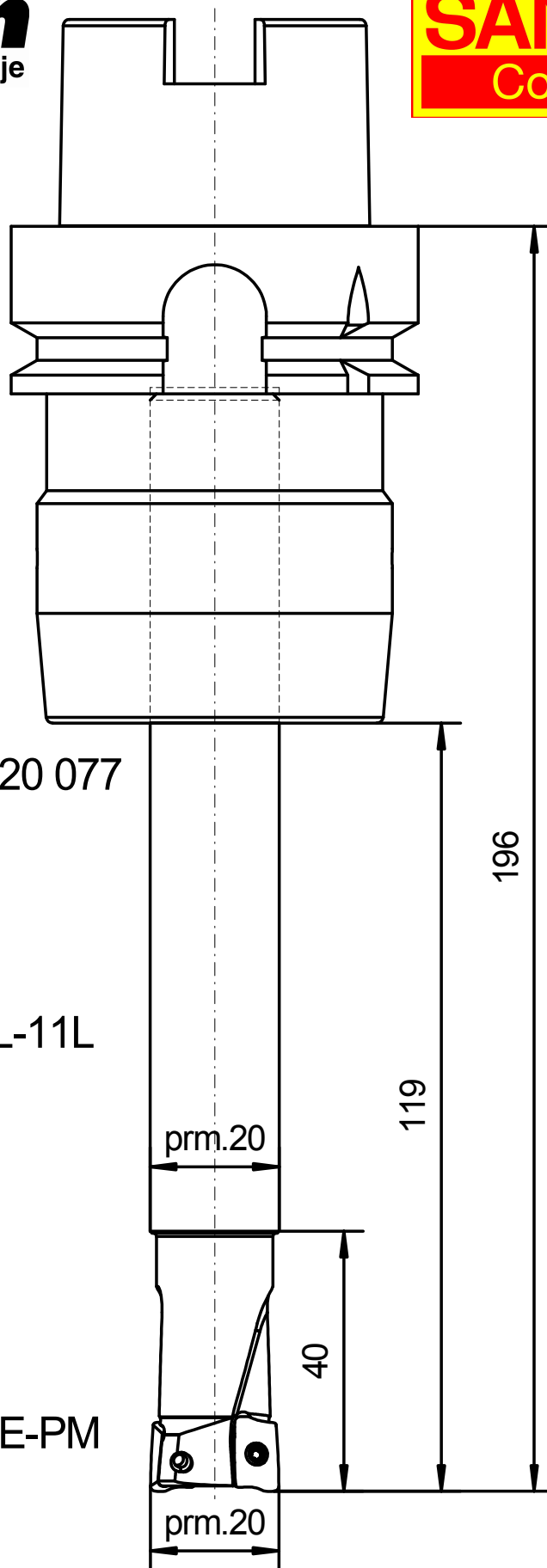

Upínač
C5-390.410-63 090C

$V_c = 130 \text{ m/min}$
 $f_z = 0,1 \text{ mm}$
 $a_p = 5 \text{ mm}$
 $a_e = 5 \text{ mm}$

Fréza tlumená
R390D-020C5-11L125

VBD
R390-11T304E-PL 1030

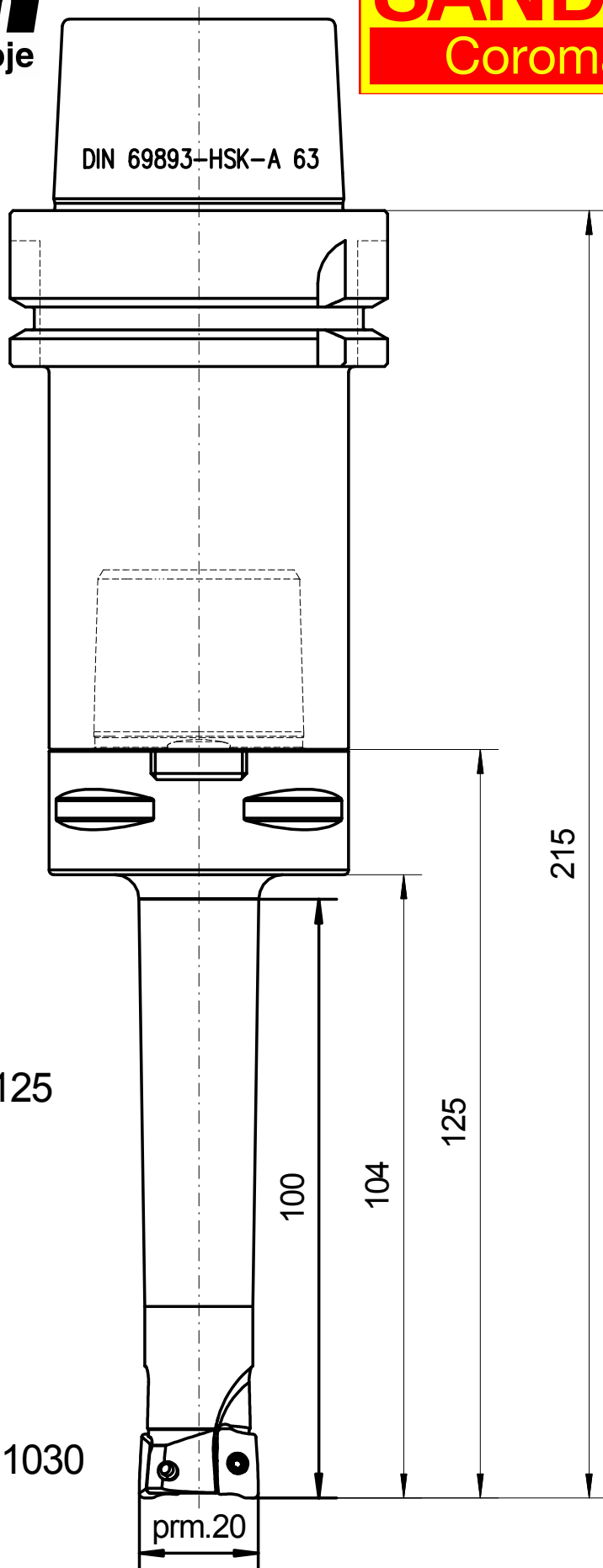

Tlumený upínač
392.410TD-63 16 280A

SANDVIK
Coromant

s.r.o. **Misan**
Obráběcí stroje a nástroje

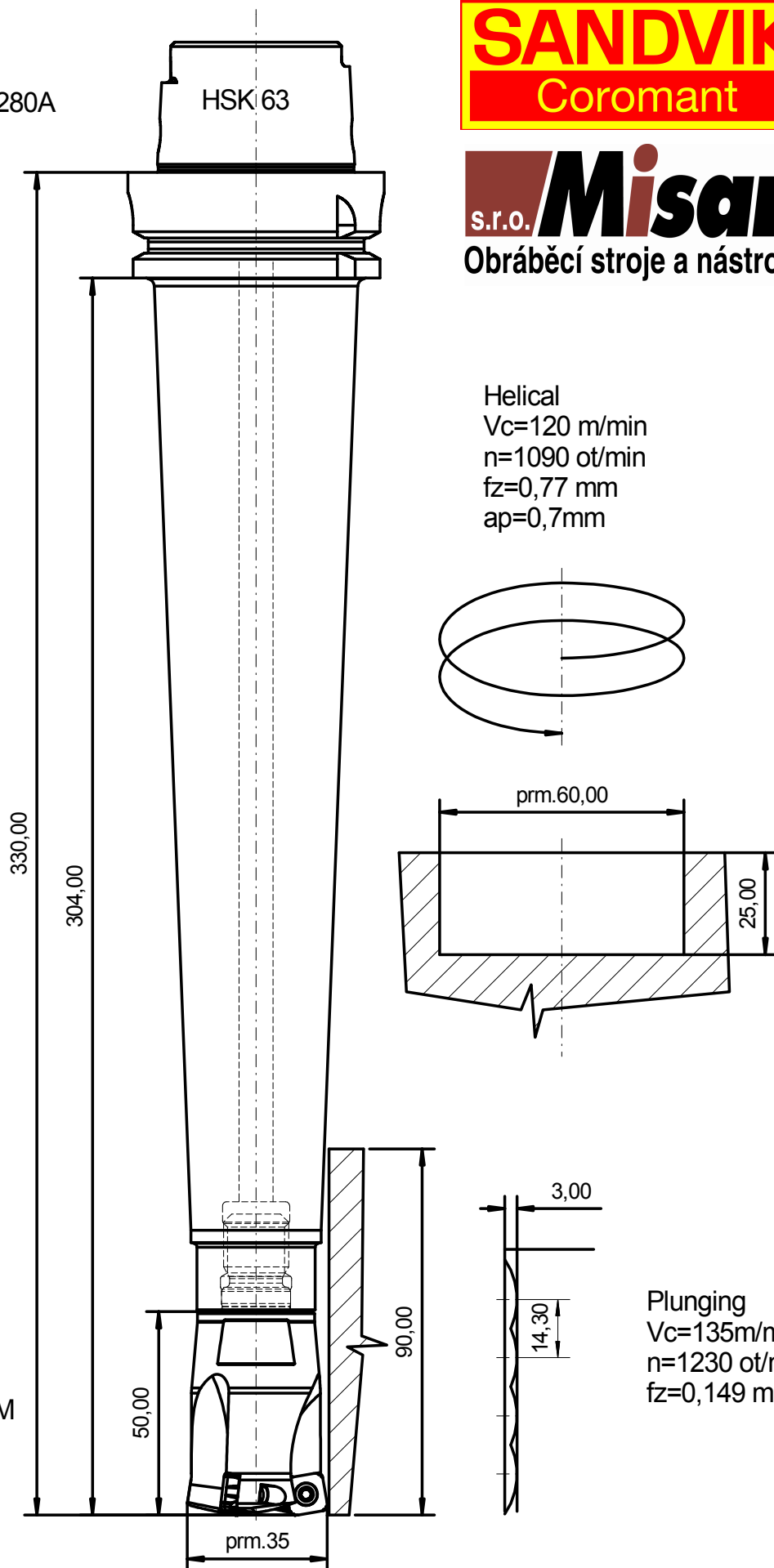

Fréza
R210-035T16-09H
z=3

VBD
R210-09 04 14E-PM
1030

Plunging
Vc=135m/min
n=1230 ot/min
fz=0,149 mm